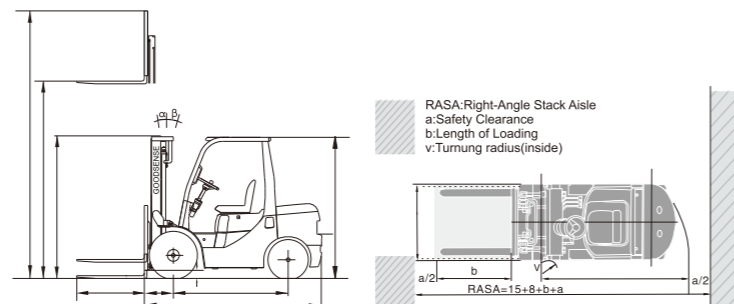
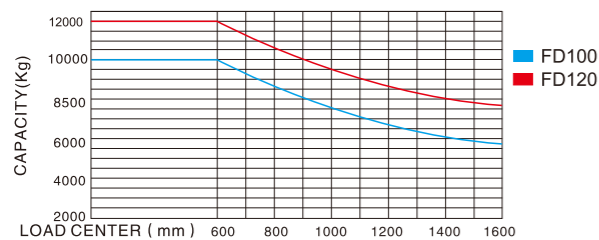

G-SERIES DIESEL FORKLIFT 10.0-12.0 TON

General	1	Model	FD100	FD100	FD120	FD120		
	2	Power Type	Diesel	Diesel	Diesel	Diesel	Diesel	
3	Rated Capacity	kg	10000	10000	12000	12000		
4	Load Centre	mm	600	600	600	600		
Characteristic&Dimension	5	Lift Height	mm	3000	3000	3000	3000	
	6	Fork Size	L×W×T	1520x175x85	1520x175x85	1520x180x100	1520x180x100	
	7	Mast Tilt Angle	F/R	6°/12°	6°/12°	6°/12°	6°/12°	
	8	Front Overhang (Wheel center to fork face)	mm	750	750	770	770	
	9	Ground Clearance (Bottom of mast)	mm	240	240	250	250	
	10-14	Overall Dimension	Length to face of fork(Without fork)	mm	4280	4280	4700	4700
			Overall Width	mm	2170	2170	2200	2200
			Mast Lowered Height	mm	2830	2830	3080	3080
			Mast Extended Height(With backrest)	mm	4300	4300	4540	4540
			Overhead Guard Height	mm	2570	2570	2590	2590
	15	Turning Radius (outside)	mm	3970	3970	4700	4700	
	16	Min. insecting aisle	mm	3590	3590	4200	4200	
	Performance	17	Speed	Travel (Empty load)	km/h	30	30	30
				Lifting(Full load)	mm/s	270	270	280
		19	Max.Gradeability	%	20	20	20	20
Chassis	20	Tire	Front	mm	9.00-20-14 PR	9.00-20-14 PR	9.00-20	
			Rear	mm	9.00-20-14 PR	9.00-20-14 PR	9.00-20	
	22	Wheelbase	mm	2800	2800	3200	3200	
	23	Service weight	kg	13000	13000	14500	14500	
Power&Transmission	24	Battery	Voltage/Capacity	V/Ah	(12V/80AH)x2	(12V/80AH)x2	(12V/80AH)x2	
	25-32	Engine	Model		6BG1	CA6110/125-HL10	QSB4.5-C130	
			Manufacture		ISUZU	XICHAI	CUMMINS	
			Rated output/r.p.m.	kw	82.3/2000	83/2000	97/2200	
			Rated torque/r.p.m.	N·m	416/1400-1600	450/1400-1500	622/1500	
			No.of Cylinder		6	6	4	
			Bore×Stroke	mm	105x125	110x125	107x124	
			Displacement	cc	6494	7127	4500	
			Fuel Tank Capacity	L	140	135	150	
	33	Transmission	Type		Hydraulic	Hydraulic	Hydraulic	
			Stage	FWD/RVS	2/2	2/2	2/2	
	34	Operating Pressure for Attachment	Mpa	19	19	19	19	

10.0-12.0 TON DIESEL FORKLIFT MAST

Type	Model	Lift Height (mm)	Load Capacity (kg)		Overall Height (mm)				Free Lift (mm)		Tilt Angle
					10.0t		12.0t		10.0t	12.0t	
			10.0t	12.0t	Mast Lowered	Mast Extended	Mast Lowered	Mast Extended	Mast Extended	Mast Extended	F/R
Wide view 2-stage mast	M250	2500	10000	-	2580	4070	-	-	-	-	6/12
	M300	3000	10000	12000	2830	4260	3080	4510	-	-	6/12
	M330	3300	10000	12000	2980	4560	3230	4810	-	-	6/12
	M350	3500	10000	12000	3080	4760	3330	5010	-	-	6/12
	M370	3700	10000	12000	3180	4960	3455	5260	-	-	6/12
	M400	4000	10000	11000	3380	5310	3630	5560	-	-	6/12
	M450	4500	10000	11000	3630	5810	3880	6060	-	-	6/6
	M500	5000	10000	10000	3880	6310	4130	6560	-	-	6/6
	M550	5500	9000	9500	4180	6860	4430	7110	-	-	3/6
	M600	6000	8000	8500	4430	7360	4680	7610	-	-	3/6
Full free mast 3-stage mast	S360	3600	8000	-	2600	4920	-	-	1205	-	6/12
	S400	4000	8000	-	2725	5320	-	-	1330	-	6/6
	S435	4350	8000	-	2850	5670	-	-	1455	-	6/6
	S450	4500	8000	-	2900	5820	-	-	1505	-	6/6
	S480	4800	7500	-	3000	6120	-	-	1605	-	6/6
	S500	5000	7500	-	3100	6320	-	-	1705	-	6/6
	S550	5500	7000	-	3270	6820	-	-	1875	-	3/6
	S600	6000	6500	-	3525	7320	-	-	2130	-	3/6

**DIESEL FORKLIFT
10.0-12.0Ton**
